

Using the FBC-001-NL Optical Fiber Cleaver

1. General

1.1 The FBC-001-NL Fiber Cleaver uses the score and snap method to quickly provide good quality fiber cleaves for fusion or mechanical splicing (Figure 1).

1.2 This procedure assumes that you have stripped and cleaned the fiber to be cleaved according to the appropriate fiber stripping procedure.

1.3 If this document is reissued, a summary of changes will appear in this paragraph.

2. Precautions

Safety Glasses

WARNING: It is strongly recommended that you wear safety glasses to protect your eyes from accidental injury when handling chemicals, cutting fiber, or using compressed air to clean this cleaver. Pieces of glass fiber are very sharp and can damage the cornea of the eye easily.

Glass Fiber Precautions

WARNING: Cleaved glass fibers are very sharp and can pierce the skin easily. Do not let cut pieces of fiber stick to your clothing or drop in the work area where they can cause injury later. Use tweezers to pick up cut or broken pieces of the glass fibers and place them on a loop of tape kept for that purpose alone. Good house-keeping is very important.

3. Tools and Materials

3.1 In addition to the cleaver, you will need the following items:

- Vinyl tape
- Tweezers

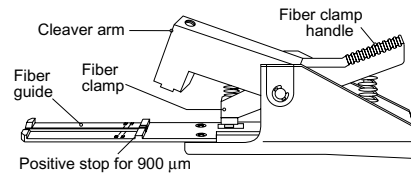

Figure 1

4. Procedure

4.1 Press down on the handle to open the cleaver's fiber clamp (Figure 2).

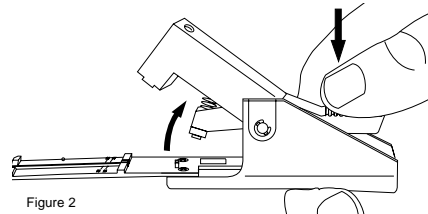

Figure 2

4.2 With your other hand, place the fiber(s) in the fiber guide so that the end of the fiber is under the fiber clamp and the end of the fiber coating lines up with the desired cleave length marking (Figure 3).

DO NOT FLEX THE FIBER GUIDE AT THIS TIME.

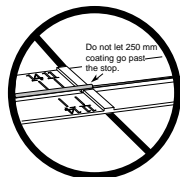
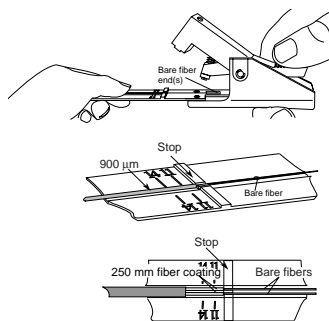

Figure 3

4.3 Gently release the handle to lower the clamp onto the bare fiber(s).

4.4 Press down the cleaver arm until it just touches the fiber and guide (Figure 4). This will apply enough pressure to properly score the fiber(s).

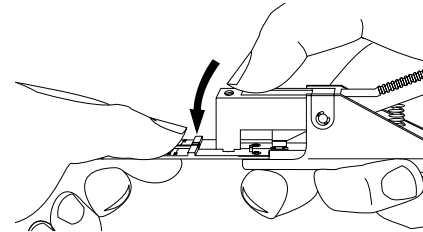

Figure 4

4.5 Gently release the cleaver arm.

4.6 Flex the fiber guide to snap the fiber(s) (Figure 5). The fiber is now ready for splicing.

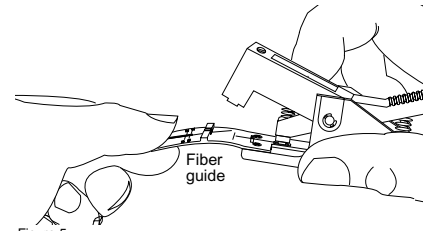

Figure 5

4.7 Press down on the cleaver's handle to once again lift the fiber clamp. Remove the end piece of fiber with tweezers and place the fiber on a loop of tape for proper disposal (Figure 6).

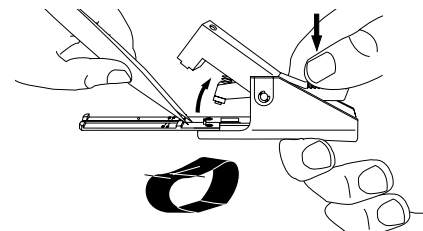

Figure 6

5. Maintenance

5.1 Thoroughly clean the cleaver after each use. Small fiber remnants left in the cleaver may cause damage to parts during later use.

5.2 Periodically clean the cleaver's blade, fiber guide, and fiber clamp with an alcohol-soaked wipe, followed by a cleaning with compressed air. **ALWAYS WEAR EYE PROTECTION WHEN CLEANING WITH COMPRESSED AIR.**